

AKAVEE

INSTRUCTIONS

FULL

FUNCTION

STEAM IRON

AKV-1009-GS

220-240V~, 50-60Hz, 1180-1400W



IMPORTANT SAFETY INSTRUCTIONS

When using your flatiron, basic safety precautions should always be followed, including the following:

READ ALL INSTRUCTIONS BEFORE USING

1. Use iron only for its intended use.
2. To protect against a risk of electric shock, do not immerse the iron in water or other liquids.
3. The iron should always be turned to ‘ **Off** ’ before plugging or unplugging from outlet. Never yank cord to disconnect from outlet; instead, grasp plug and pull to disconnect.
4. Do not allow cord to touch hot surfaces. Let iron cool completely before putting away. Loop cord loosely around iron when storing.
5. Always disconnect iron from electrical outlet when filling with water or emptying and when not in use.
6. Do not operate iron with a damaged cord or if the iron has been dropped or damaged. To avoid the risk of electric shock, do not disassemble the iron take it to a qualified serviceman for examination and repair. Incorrect reassembly can cause a risk of electric shock when the iron is used.
7. Close supervision is necessary for any appliance being used by or near children. Do not leave iron unattended while connected or on an ironing board.
8. Burns can occur from touching hot metal parts, hot water, or steam. Use caution when you turn a steam iron upside down – there may be hot water in the reservoir.
9. If the malfunction indicator goes on, the flatiron is not operating normally. Disconnect from the power supply and have the flatiron serviced by qualified service personnel.

SPECIAL INSTRUCTIONS

1. To avoid a circuit overload, do not operate another high wattage appliance on the same circuit.
2. If an extension cord is absolutely necessary, a 10-ampere cord should be used. Cords rated for less amperage may overheat. Care should be taken to arrange the cord so that it cannot be pulled or tripped over.

SAVE THESE INSTRUCTIONS

More specifically:

- DO NOT** let children or untrained persons use the appliance without supervision.
- NEVER** immerse the iron, cable or plug in any liquid.
- DO NOT** leave the hot iron touching fabrics or very inflammable surfaces.
- DO NOT** leave the appliance unnecessarily plugged in. Disconnect the plug from the mains when the appliance is not being used.
- NEVER** touch the appliance with wet or damp hands.
- DO NOT** use the power cord or the appliance in order to pull the plug out of the socket.

DO NOT leave the appliance exposed to the weather (rain, sun, etc.).
DO NOT leave the iron without supervision when it is connected to the power supply.

PLEASE NOTE!

Do not use chemical additive, scented substances or decalcifiers. Failure to comply with the above-mentioned regulations leads to the loss of guarantee.

DESCRIPTION OF DEVICE

- | | |
|---|----------------------------|
| (1) . Soleplate with steam vents | (2). Skirt |
| (3). Transparent handle with water tank | (4). Maximum filling level |
| (5) . Soleplate temperature control light | (6). Handle cover |
| (7) . Thermostat knob | (8). push-button |
| (9) . Steam dial | (10). Filler door |
| (11) . Spray organ | (12) . Supply cord |
| (13). Cord bushing | (14).Water measure |

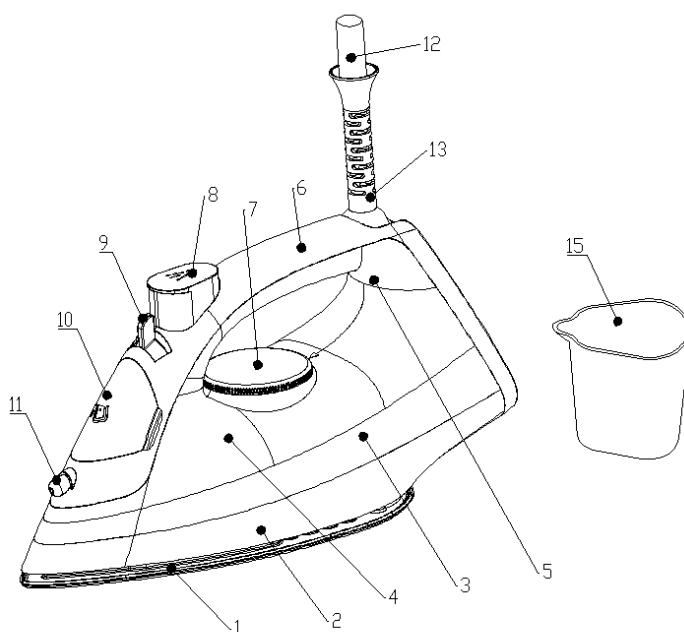

SPECIFIC FUNCTION DESCRIPTION

This feature is available only if you select it. Otherwise, it is not available.

Please note:

Use tap water only. Distilled and/demineralised water makes the anti-calc system ineffective by altering its physicochemical characteristics.





Do not use chemical additives, scented substances or decalcifiers. Failure to comply with the above-mentioned regulations leads to the loss of guarantee.

GENERAL INSTRUCTIONS

When using the iron for the first time, you may notice a slight emission of smoke and hear some sounds made by the expanding plastics. This is quite normal and it stops after a short time. We also recommend passing the iron over an ordinary cloth before using it for the first time.

PREPARATIONS

Soft the laundry to be ironed according to the international symbols on the garment label, or if this is missing, according to the type of fabric.

GARMENT LABEL	FABRIC TYPE	THERMOSTAT REGULATION
	synthetic	• low temperature
	silk - wool	•• medium temperature
	Cotton - linen	••• high temperature
	Fabric not to be ironed	

Start ironing the garments requiring a low temperature.

This reduces the waiting times (the iron takes less time to heat up than to cool down) and eliminates the risk of scorching the fabric.

STEAM IRONING

Filling the reservoir

- Check that the plug is disconnected from the socket.
- Move the steam selector (9) to “” [Fig. 1].
- Open the lid (10) .
- Raise the tip of the iron to help the water enter the opening without overflowing.
- Slowly pour the water into the reservoir using the special measure (14) and taking care not to go over the maximum level (about 220ml) indicated by “max” on the reservoir [Fig. 2].
- Close the lid (10) .



Selecting the temperature.

- Put the iron in a vertical position.
- Put the plug in the socket.
- Adjust the thermostat knob (7) according to the international symbol on the garment label [Fig. 3]. The soleplate temperature control light (5) indicates that the iron is heating up. Wait until the soleplate temperature control light goes off before ironing.

Warning: *during ironing, the soleplate temperature control light (5) comes on at intervals, indicating that the selected temperature is maintained. If you lower the thermostat temperature after ironing at a high temperature, do not start ironing until the soleplate temperature control light comes on again.*

Selecting the steam.

The quantity of steam is regulated by the steam selector (9) .

- Move the steam selector to a position between  and ECO and  depending on the quantity of steam required and the temperature selected [Fig. 1].[Fig. 5]

Warning: *the iron gives off steam continuously only if you hold the iron horizontally. You can stop the continuous steam by placing the iron in a vertical position or by moving the steam selector to “”.* As indicated on the thermostat knob (7) and in the initial table, you can only use steam at the highest temperatures. If the selected temperature is too low, water may drip onto the plate.

Warning: *the shot-steam function can only be used at high temperatures. Stop the emission when the soleplate temperature control light (5) comes on, than start ironing again only after the light has gone off.*

DRY IRONING

To iron without steam, follow the instructions in section “steam ironing”, leaving the steam selector (9) on position “”.

Spray Function

Make sure that there is water in the reservoir. Press the spray button (8) slowly (for a dense spray) or quickly (for a vaporized spray) [Fig. 4].

Warning: *for delicate fabrics, we recommend moistening the fabric beforehand using the spray function (8), or putting a damp cloth between the iron and the fabric. To avoid staining, do not use the spray on silk or synthetic fabrics.*

CLEANING

Please note: before cleaning the iron in any way, make sure that the appliance plug is not connected to the socket.

Any deposits, starch residue or size left on the plate can be removed using a damp cloth or an unabrasive liquid detergent.

Avoid scratching the plate with steel wool or metallic objects.

The plastic parts can be cleaned with a damp cloth then wiped over with a dry cloth.

HOW TO PUT IT AWAY

- Disconnect the plug of the iron from the socket.
- Empty the reservoir by turning the iron upside down and gently shaking it.
- Leave the iron to cool down completely.
- Roll up the power cord with the rewinder [Fig. 6].
- Always put the iron away in a vertical position.

ADVICE FOR GOOD IRONING

We recommend using the lowest temperatures with fabrics that have unusual finishes (sequins, embroidery, flush, etc.).

If the fabric is mixed (e.g. 40% cotton 60% synthetics), set the thermostat to the temperature of the fibre requiring the lower temperature.

If you don't know the composition of the fabric, determine the suitable temperature by testing on a hidden corner of the garment. Start with a low temperature and increase it gradually until it reaches the ideal temperature.

Never iron areas with traces of perspiration or other marks: the heat of the plate fixes the stains on the fabric, making them irremovable.

The size is more effective if you use a dry iron at a moderate temperature: excess heat scorches it with the risk of forming a yellow mark.

To avoid marking silk, woolen or synthetic garments shiny, iron them inside out.

To avoid marking velvet garments shiny, iron in one direction (following the fibre) and do not press down on the iron.

The heavier the washing machine is loaded, the more garments come out creased. This also happens when the spin drying revolutions are very high.

Many fabrics are easier to iron if they are not completely dry.

For example, silk should always be ironed damp.

